

# MASTER THESIS WITHIN ACTUATOR MODEL FOR FLOW CONTROL

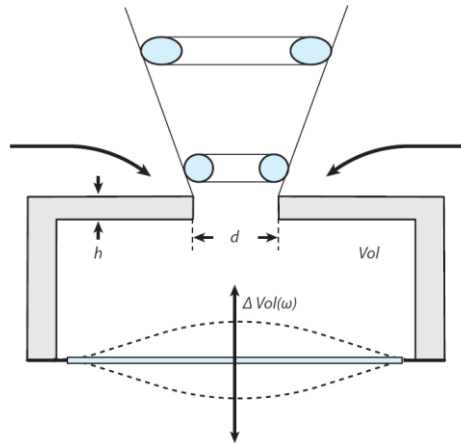

Creo Dynamics is a Swedish company working with product innovations, research and consulting. We combine acoustics, aerodynamics and structural dynamics to make use of the synergies there between, to develop new ideas and innovative products, e.g. applications for active noise & vibration control, active flow control for cars and Structural Health Monitoring.

Today, Creo consists of 17 co-workers with roots from the aerospace and automotive industries. We participate in complex development projects and we are passionate about pioneering and innovative solutions.

We strive to be the best and to continuously further our skills. This is why we sharpen our competences by participating and contributing in national and international research projects. Visit our website for more information about our company: [www.creodynamics.com](http://www.creodynamics.com)

**Please see next page for thesis description!**

**Place:** Linköping

**Time:** january 2014 – june 2014

**Contact:**

Johan Hammar

0707-256320

[johan.hammar@creodynamics.com](mailto:johan.hammar@creodynamics.com)

[www.creodynamics.com](http://www.creodynamics.com)



After years of research and development of the aerodynamic shape of ground vehicles the progress of drag reduction is becoming more and more challenging. Therefore other complex ways of controlling the flow is given more focus. One of these technics is the use of jets to impact the boundary layer and delay flow separation. At Creo Dynamics there is a wish to extend the understanding of the actuator systems that can be used for active flow control (AFC).

The objective of this work is to create a model for an actuator that can be used in the design. The performance specifications of any actuator are quantified in terms of an exhaustive list of parameters such as bandwidth, output control authority, etc. Flow-control applications benefit from a known actuator frequency response function that relates the input voltage to the output property of interest (e.g., maximum velocity, volumetric flow rate, momentum flux, etc.). Clearly, the required performance metrics are application specific, and methods are needed to achieve the optimal design of these devices.

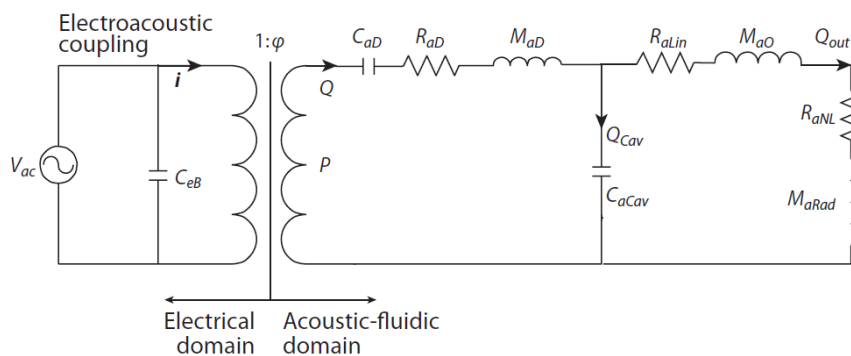

It is therefore proposed to use lumped element modeling (LEM) that is combined with equivalent circuit representations to estimate the nonlinear dynamic response of a synthetic jet as a function of device dimensions, material properties, and external flow conditions. Former work has been performed by for example Ref [1] giving promising results using this methodology.

The work will first focus on the simulation of an AFC actuator in Matlab and Simulink environment, including the integration of results from CREOs own CFD/FEM simulations of fluid and structure. In a second step, a physical demonstrator will be designed, manufactured and tested in order to validate the models.

The work implies a strong background within technical physics (Signal and system, electro-mechanics, system control) and a good knowledge of structural and fluid dynamics.

## Reference

[1] “*Design Optimization Tool for Synthetic Jet Actuators Using Lumped Element Modeling*” Quentin Gallas, Mark Sheplak and Louis N. Cattafesta III. 2005.